

WIRING DIAGRAMS
Article Text
 1987 Volkswagen Golf
 For Volkswagen Technical Site
 Copyright © 1998 Mitchell Repair Information Company, LLC
 Tuesday, December 07, 1999 11:33PM

ARTICLE BEGINNING

1987 Wiring Diagrams
 Volkswagen

 Golf & GTI

COMPONENT LOCATION MENU

COMPONENT LOCATIONS TABLE

AA

Component	Figure No. (Location)
A/C COMP CLUTCH	5 (F 17, F 19)
A/C CONTROL HEAD	5 (B-C 18)
A/C HI BLOWER RLY	5 (D-E 16)
ALTERNATOR	1 (B-C 3)
BACK-UP LT SW	4 (E 12)
BATTERY	1 (A 1)
BEAM SELECT SW	6 (B 21)
BRAKE WARN SWS	1 (E 1-2)
CENTRAL LOCKING	7 (D 24)
CIG LTR & LT	6 (A 21)
CIRC BRKR A	4 (A 13)
COLD START VALVE	1 (C 2, D 2)
CRUISE CONTROL	5 (A-C 18-19)
DEFOGGER GRID	7 (E 27)
DEFOGGER SW	5 (A-B 18)
DIR SW	6 (E 21)
DOME LT	7 (D 25-26)
DOOR SWS	7 (C-D 26)
ELECT IGN MOD (GTI)	2 (B 4)
ELECT IGN MOD (GOLF)	3 (F 8)
ENG TEMP SENDER	1 (D 3)
FLASHER RLY	6 (C 21)
FRESH AIR FAN SW	5 (B-C 16)
FUEL LEVEL SENDER	7 (D 27)
FUEL PUMP	7 (E 27)
FUEL PUMP RLY (GTI)	2 (C-D 6)
FUEL PUMP RLY (GOLF)	3 (E 11)
FUEL SHUTOFF SOL	3 (A 8)
FUS LINKS	1 (A 2-3)
FUSE PANEL	4 (C 12-15)
GLOVE COMPT LT	5 (C 19)
GLOW PLUGS	1 (D 3)
GLOW PLUG RLY	3 (D 8)
HAZARD SW	6 (C-D 20)
HI LEVEL STOP LT	7 (B 27)
HI SPD RAD FAN RLY	5 (E 19)
HORN RLY	3 (A 11)
IDLE SPEED BOOST VALVE	3 (E 9)
IDLE SPEED CONTROL RLY	3 (C 8)

WIRING DIAGRAMS
Article Text (p. 2)
 1987 Volkswagen Golf
 For Volkswagen Technical Site
 Copyright © 1998 Mitchell Repair Information Company, LLC
 Tuesday, December 07, 1999 11:33PM

IGNITION COIL (GTI)	2 (C 4)
IGNITION COIL (GOLF)	3 (B 8)
IGNITION SW	6 (A 20-21)
INST CLUSTER	6 (A-D 23)
INTERM WIPER RLY	5 (A-B 17)
KNOCK SENS CTRL UNIT (GTI)	2 (A-B 7)
LAMBDA RLY (GOLF)	3 (F 11)
LEFT FRONT DOOR SW	7 (D 26)
LIGHT SW	6 (B 20)
LOAD REDUCTION RLY	6 (A-B 20)
LOW COOLANT WARN RLY	3 (B 11)
LOW SPEED FAN RLY	5 (D 19)
NEUT SAFETY/BACK-UP LT SW	4 (E 12)
OIL PRES SWS	1 (D-E 3)
OXS CONTROL UNIT (GTI)	2 (A 5-6)
OXS CONTROL UNIT (GOLF)	3 (F 9-10)
PASSIVE RESTRAINT	6 (E-F 21-22)
POWER MIRRORS	7 (E-F 24-26)
POWER WINDOWS	7 (A-C 24-26)
PULSING RLY	1 (C 3)
RADIATOR AFTER RUN RLY	5 (E 16)
RADIATOR COOLING FAN	5 (F 16, E-F 19)
RADIO (PARTIAL)	6 (E 21)
REAR WIPER RLY & MTR	7 (E-F 24)
SEAT BELT/BRAKE WARN IND	6 (E 23)
SEAT BELT INTERLOCK RLY	6 (F 23)
STARTER	1 (A-B 3)
STARTER RLY	1 (B-C 2)
2 STAGE COLNT THERMO SW	5 (F 16, E 17)
THROTTLE VALVE SW	2 (C-D 4)
TRUNK LT	7 (B-C 27)
UPSHIFT RLY	3 (C 11, D 11)
VANITY MIRROR LT	7 (D 25)
WASHER MOTOR	5 (B 17)
WATER SEPARATOR	3 (D-E 9-10)
W/SHIELD WIPER MTR	1 (F 3)
W/SHIELD WIPER SW	5 (A-B 16)
AA	

WIRING DIAGRAM

WIRING DIAGRAMS

Article Text (p. 3)

1987 Volkswagen Golf

For Volkswagen Technical Site
Copyright © 1998 Mitchell Repair Information Company, LLC
Tuesday, December 07, 1999 11:33PM

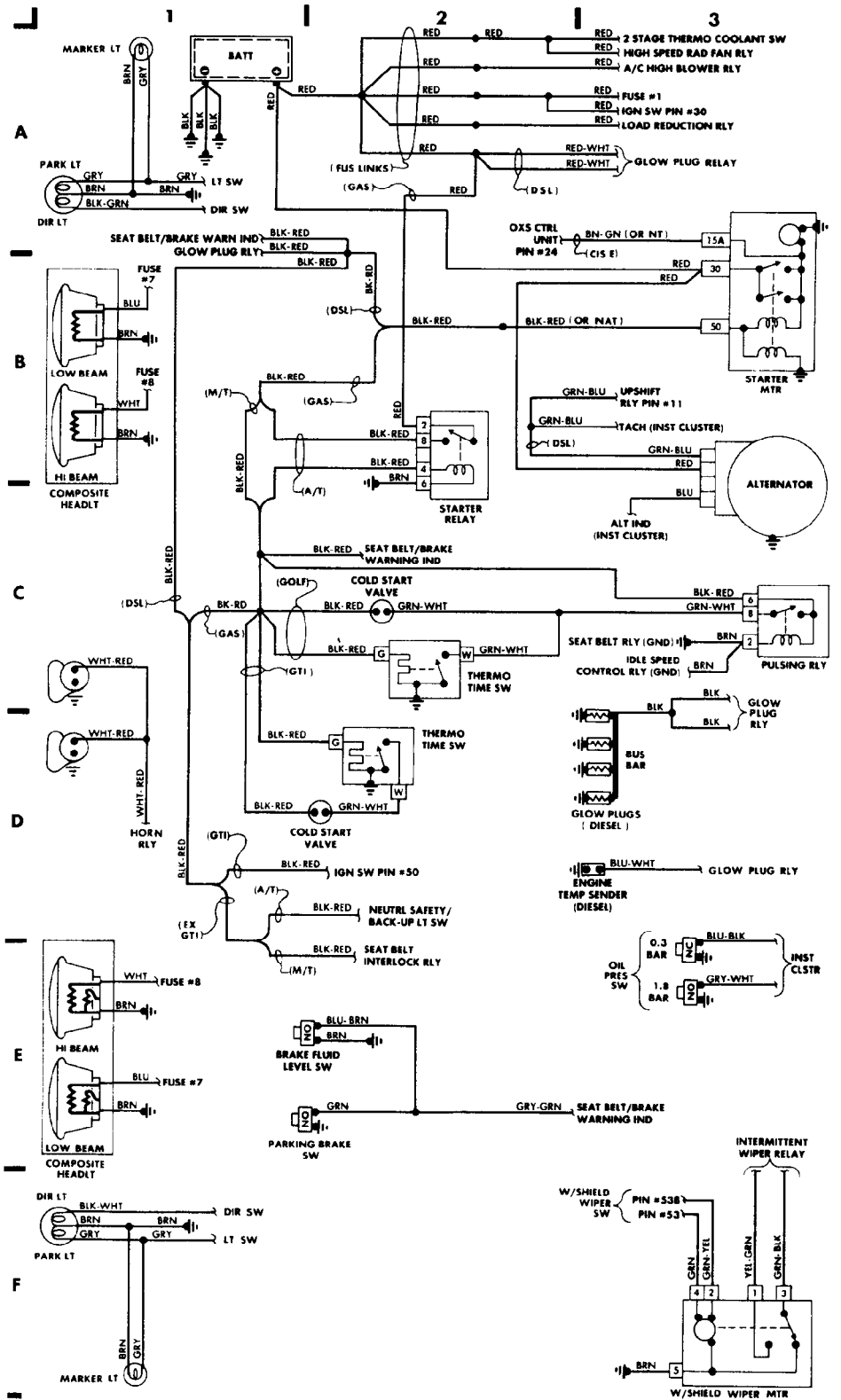

Fig. 1: Engine Compartment (Grids 1-3)

WIRING DIAGRAMS
Article Text (p. 4)
 1987 Volkswagen Golf
 For Volkswagen Technical Site
 Copyright © 1998 Mitchell Repair Information Company, LLC
 Tuesday, December 07, 1999 11:33PM

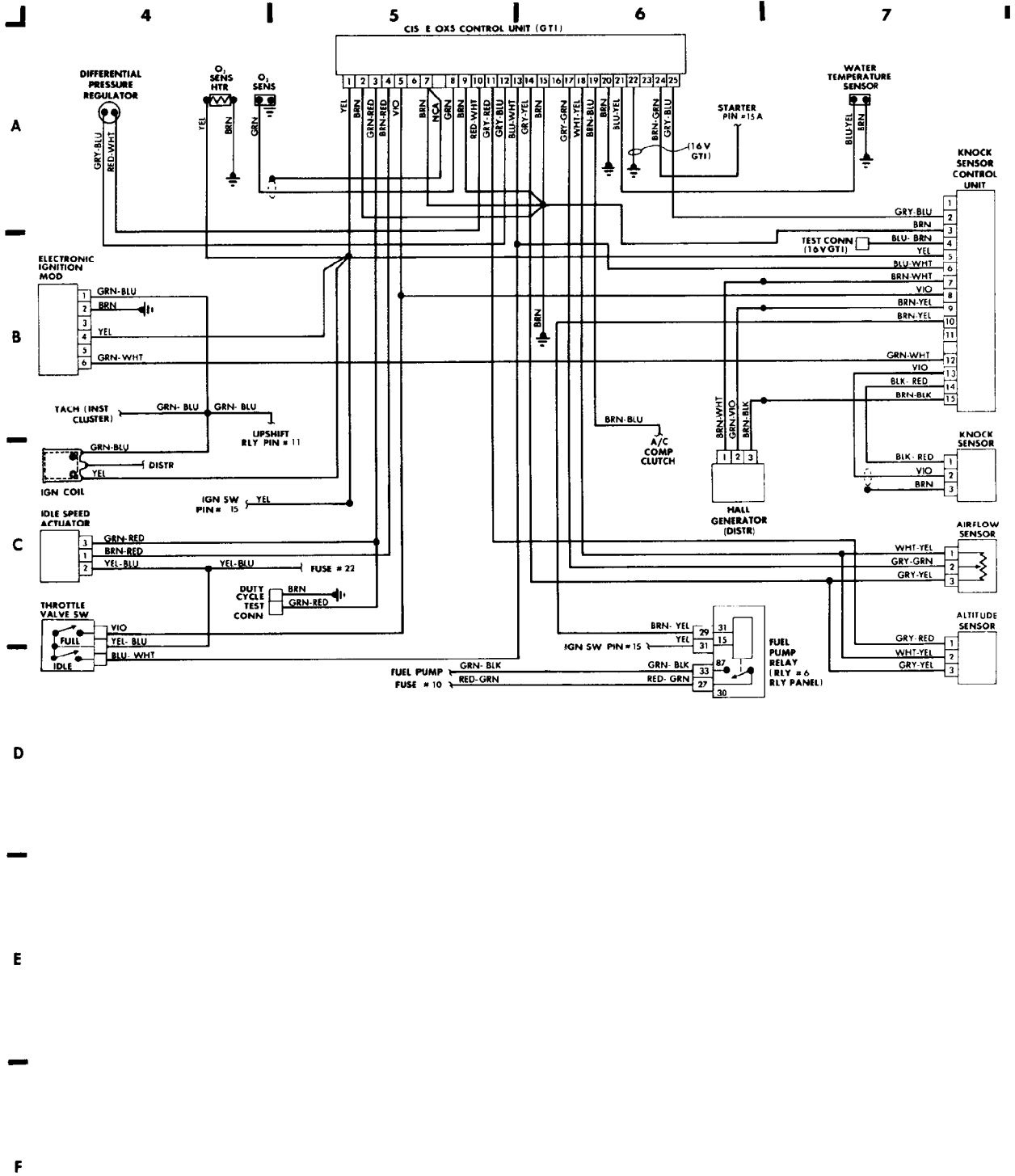

Fig. 2: Engine Compartment (Cont.) (Grids 4-7)

WIRING DIAGRAMS
Article Text (p. 5)
 1987 Volkswagen Golf
 For Volkswagen Technical Site
 Copyright © 1998 Mitchell Repair Information Company, LLC
 Tuesday, December 07, 1999 11:33PM

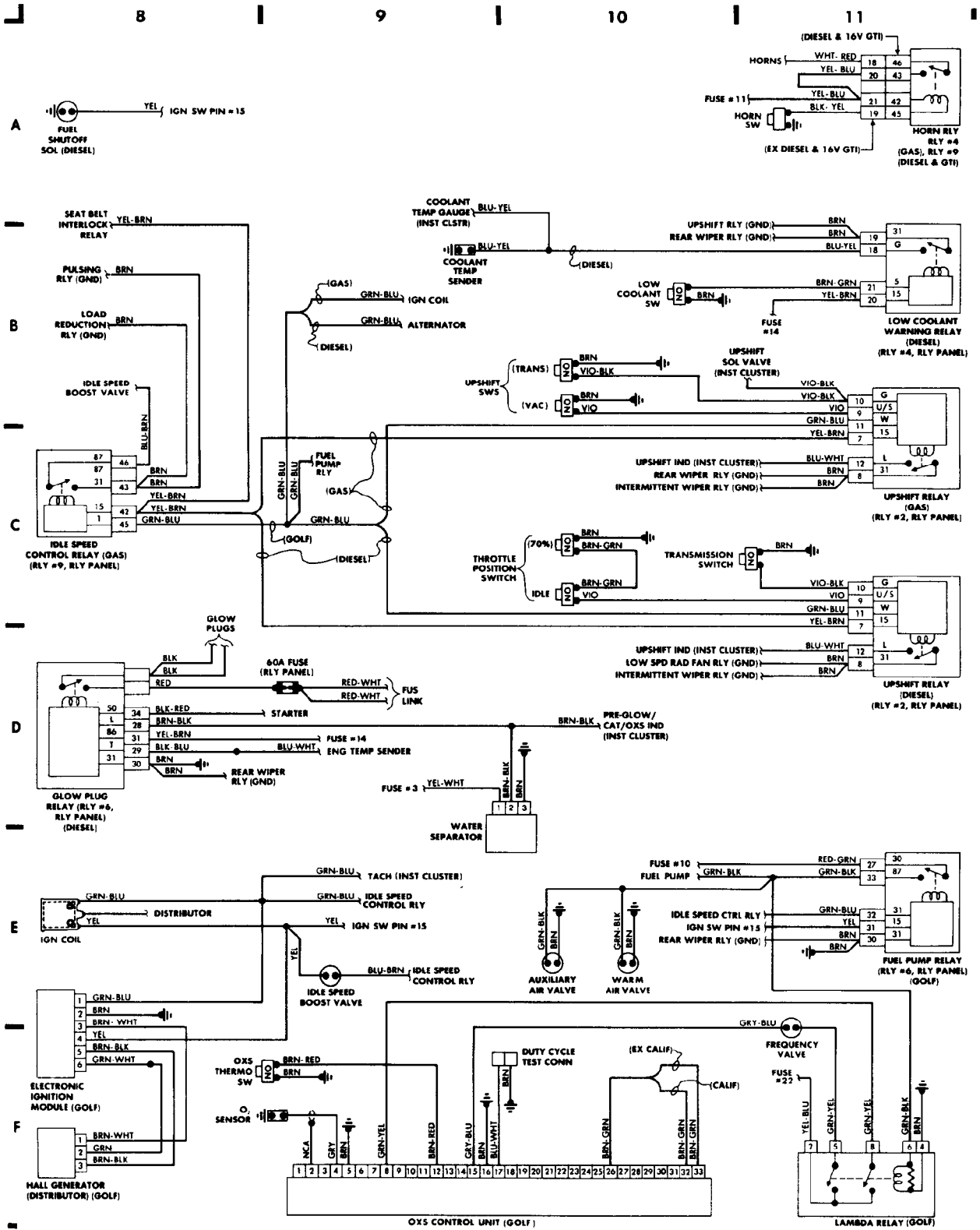

Fig. 3: Engine Compartment (Cont.) & Underdash (Grids 8-11)

WIRING DIAGRAMS
Article Text (p. 6)
 1987 Volkswagen Golf
 For Volkswagen Technical Site
 Copyright © 1998 Mitchell Repair Information Company, LLC
 Tuesday, December 07, 1999 11:33PM

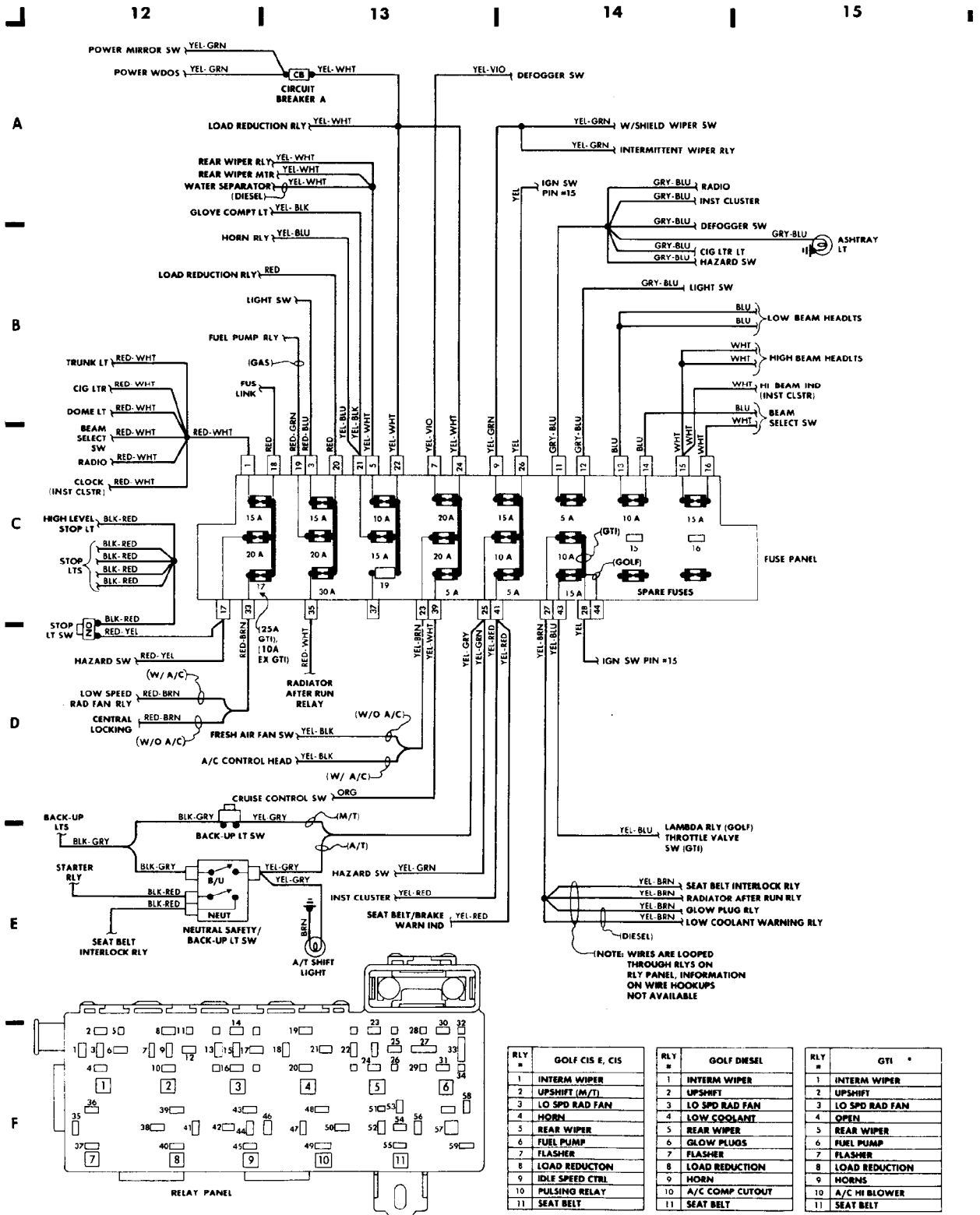

Fig. 4: Underdash (Cont.) & Fuse Block (Grids 12-15)

WIRING DIAGRAMS
Article Text (p. 7)
 1987 Volkswagen Golf
 For Volkswagen Technical Site
 Copyright © 1998 Mitchell Repair Information Company, LLC
 Tuesday, December 07, 1999 11:33PM

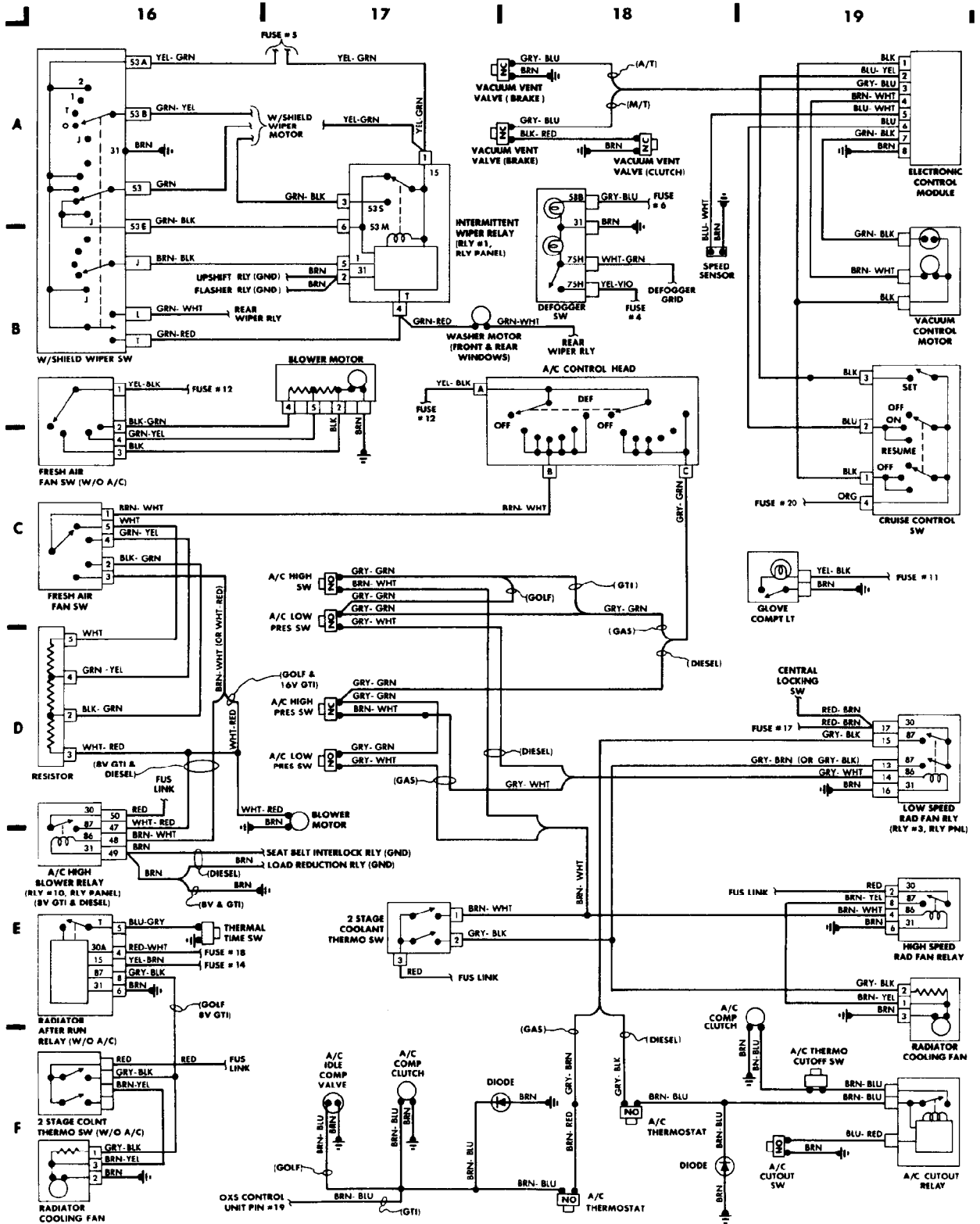

Fig. 5: Underdash (Cont.) & Instrument Panel (Grids 16-19)

WIRING DIAGRAMS
Article Text (p. 8)
 1987 Volkswagen Golf
 For Volkswagen Technical Site
 Copyright © 1998 Mitchell Repair Information Company, LLC
 Tuesday, December 07, 1999 11:33PM

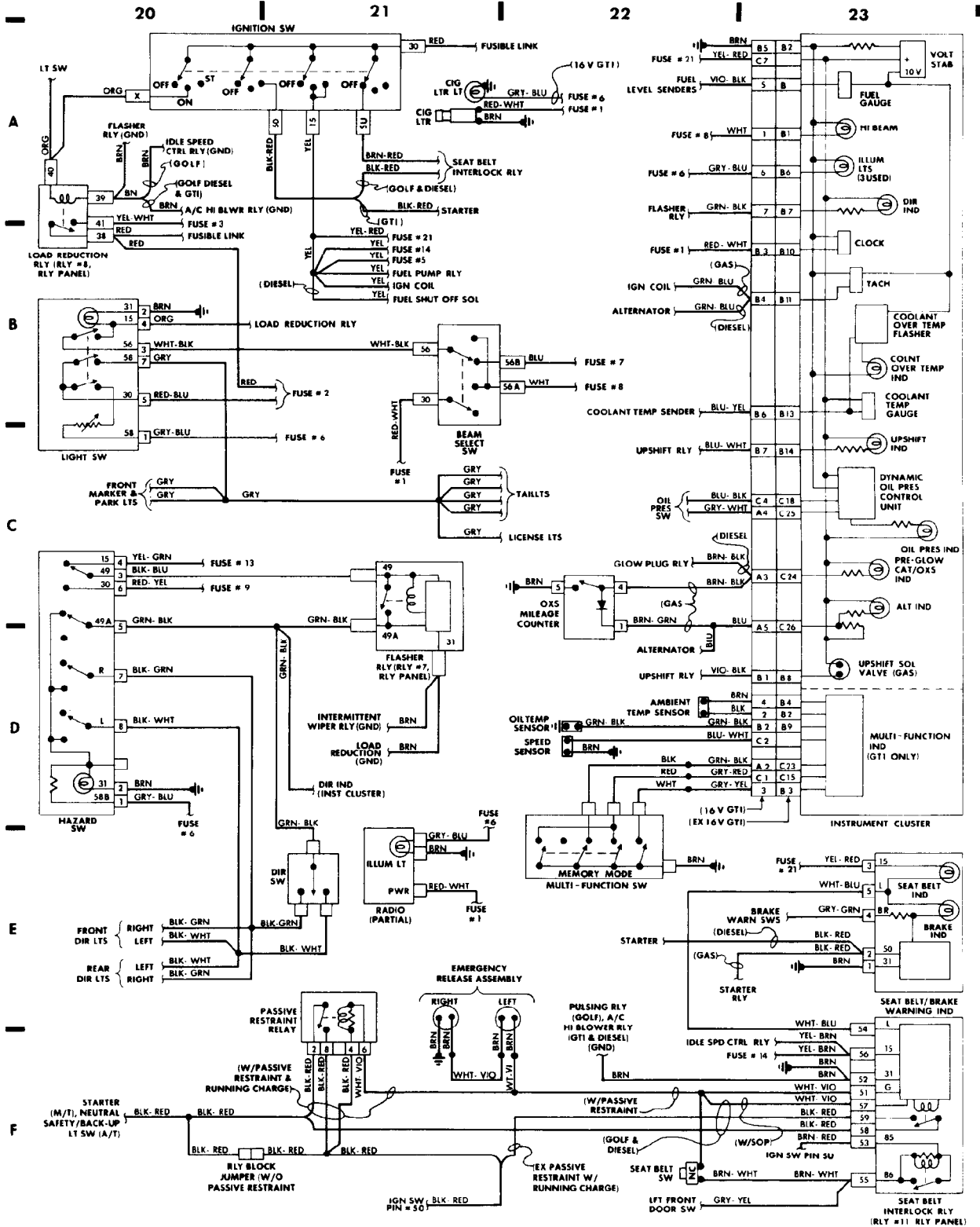

Fig. 6: Instrument Panel (Cont.) (Grids 20-23)

WIRING DIAGRAMS

Article Text (p. 9)

1987 Volkswagen Golf

For Volkswagen Technical Site
Copyright © 1998 Mitchell Repair Information Company, LLC
Tuesday, December 07, 1999 11:33PM

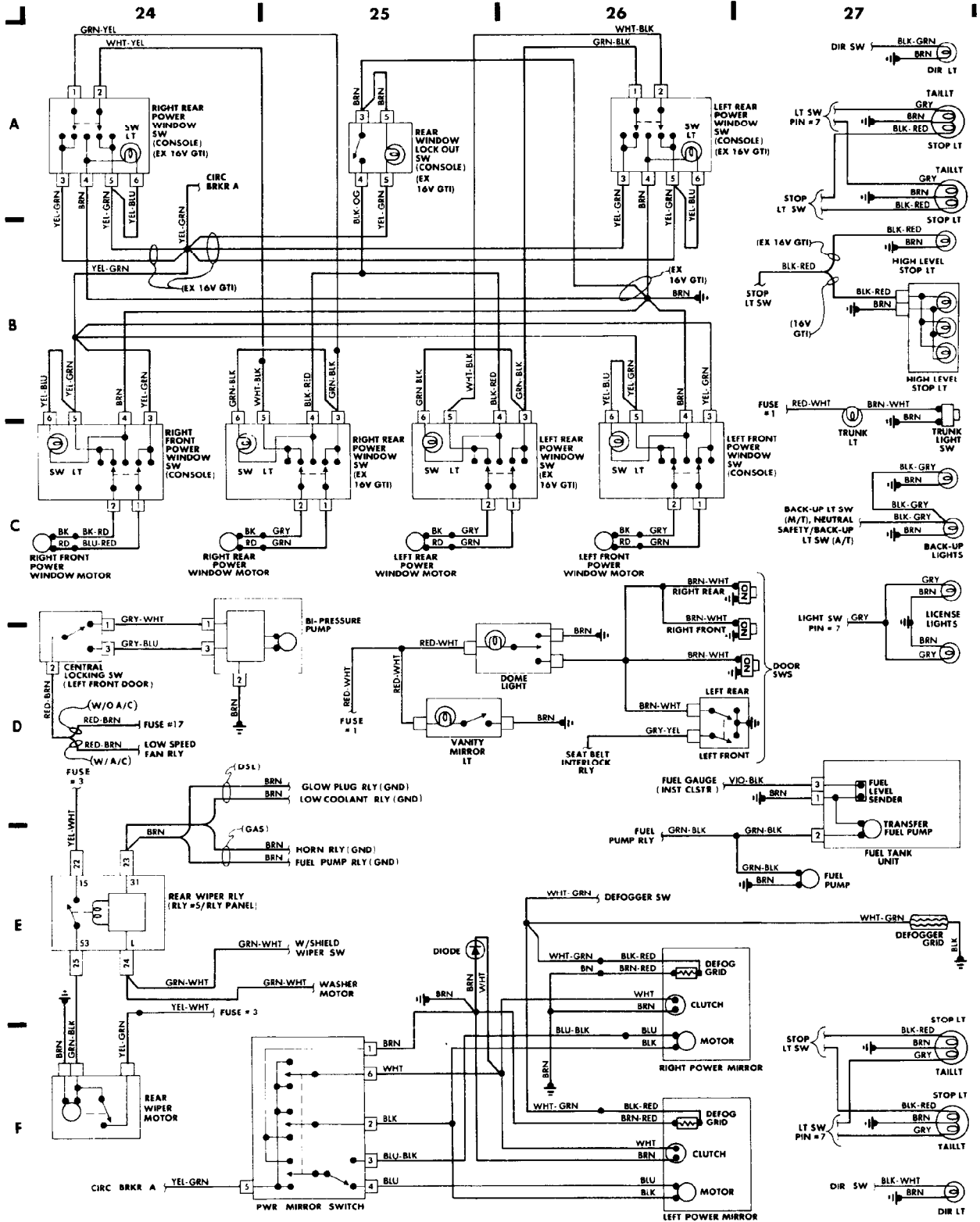

Fig. 7: Rear Compartment & Accessories (Grids 24-27)

END OF ARTICLE